

## Type SBSB Module

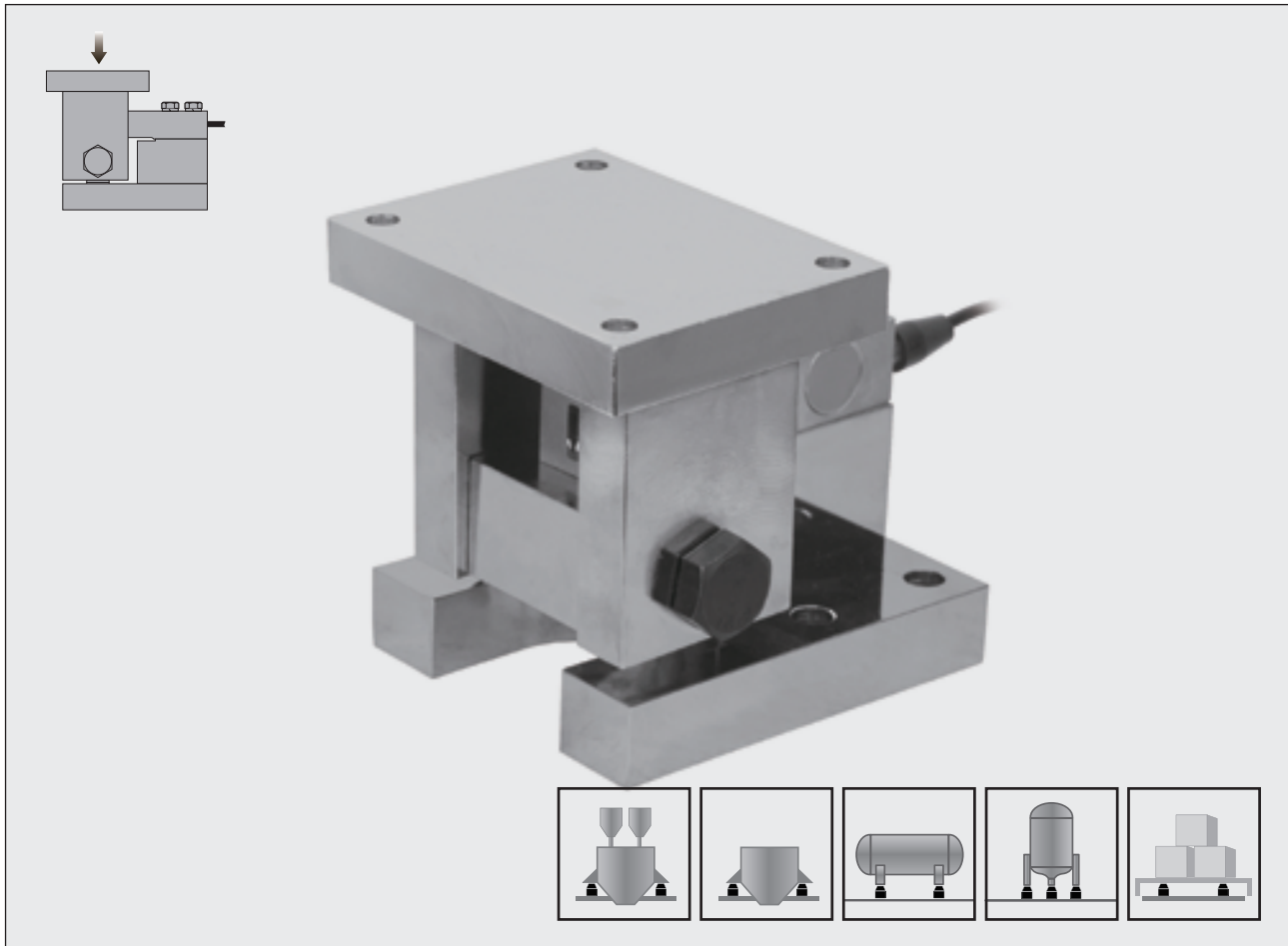

### Features 主要特点

- Stainless steel construction
- Mounts to structural support directly
- Easy to Install, Stable, Reliable & safety limit
- SBSB (single ended shear beam stainless steel load cell) installed
- Anti-explosion load cell (option)
- Fit for reactor, floor scales, blending & mixing systems and batching systems, etc
- 不锈钢结构
- 可直接安装在基础结构上
- 安装简便、快速，稳定可靠，并具过载保护
- 使用悬臂梁SBSB不锈钢传感器
- 防爆传感器（可选）
- 适用于反应罐、平台秤、搅拌站和配料秤等

### Schematic 接线方式

Red :	+ input	红色 :	+ 激励
Black :	- input	黑色 :	- 激励
Green :	+ output	绿色 :	+ 信号
White :	- output	白色 :	- 信号

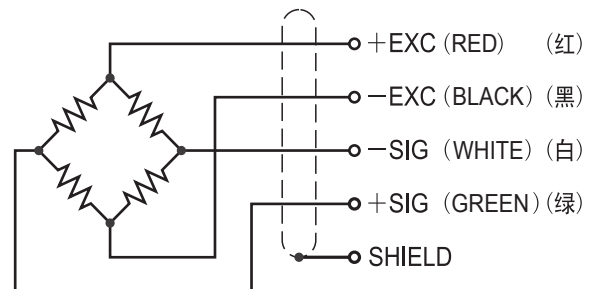

### Capacities 量程

250lb, 250kg, 500kg, 1000kg, 1500kg, 2000kg, 2500kg  
5000kg

**Dimensions** 尺寸

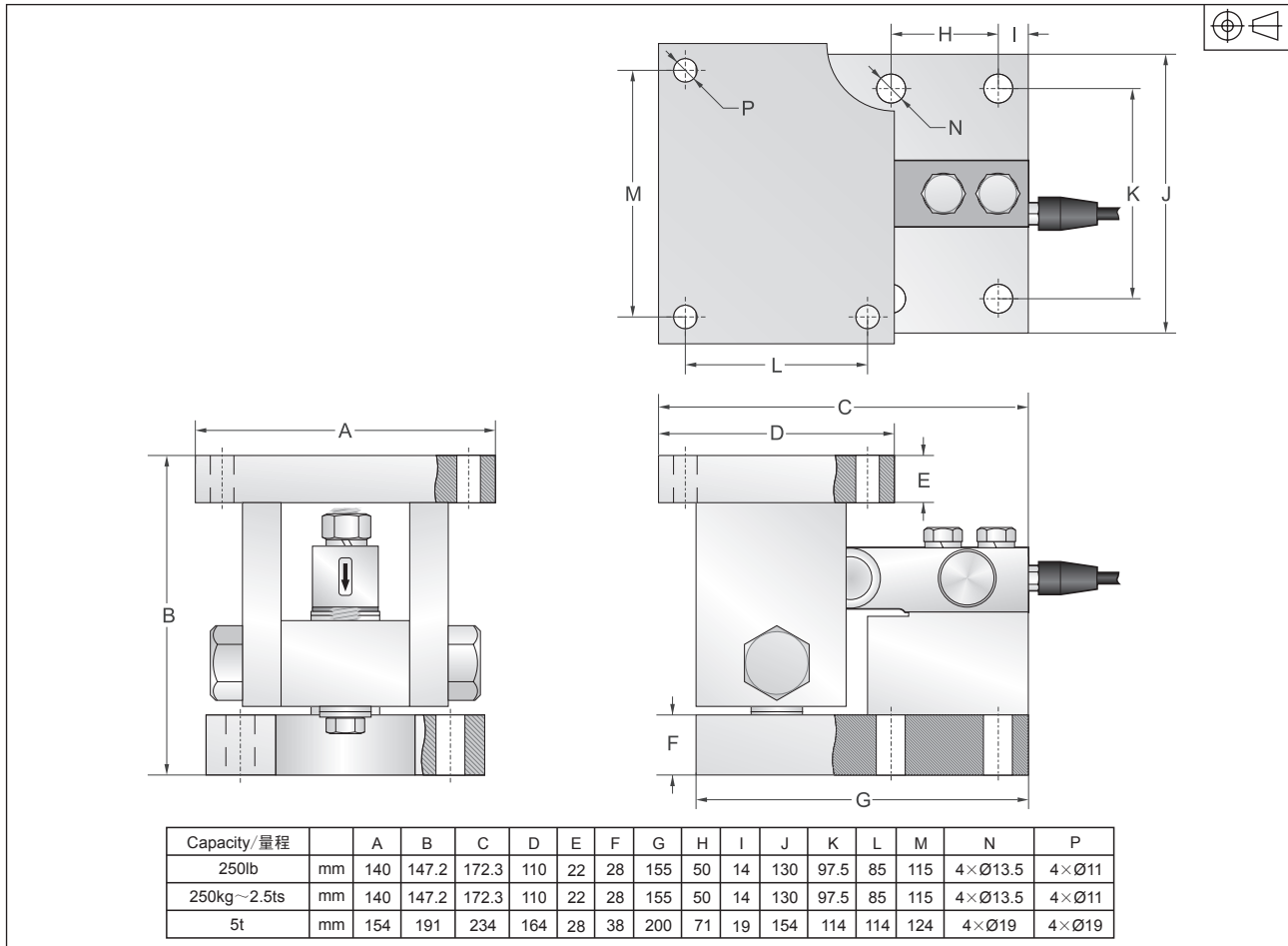

**Specification** 技术参数 (SBSB)

Rated Output	额定输出	2.0mV/V ±0.1% / 3.0mV/V ±0.1%
Zero Balance	零点平衡	±1% of rated output
Creep after 30 minutes	蠕变	±0.03% of rated output
Nonlinearity	非线性	±0.03% of rated output
Hysteresis	滞后	±0.03% of rated output
Repeatability	重复性	±0.03% of rated output
Temp. effect on output	灵敏度温漂	≤0.002% of applied output/°C
Temp. effect on zero	零点温漂	≤0.002% of rated output/°C
Safe Temp. Range	可用温度范围	-10°C to + 70°C
Temp. Compensated	温度补偿范围	-10°C to + 40°C
Safe Overload	安全载荷	150%
Input Impedance	输入阻抗	387 ohm ± 20 ohm
Output Impedance	输出阻抗	350 ohm ± 5 ohm
Insulation Resistance	绝缘阻抗	≥5000 M ohm (50V DC)
Rated Excitation	推荐激励电压	10V DC/AC
Maximum Excitation	最大激励电压	15V DC/AC
Cable Length	导线长度	6m
Cable Color Code	导线颜色	Red(+ E) Black(-E) Green(+ S) White(-S)

Weighing Modules